

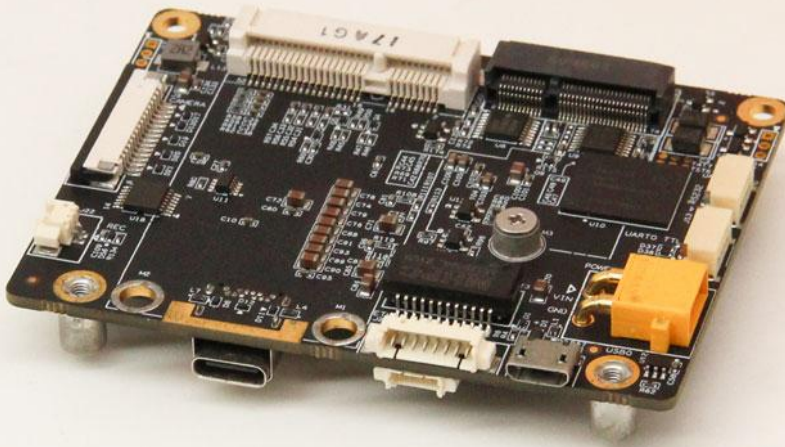

AI Development Carrier Board

Y-C7

Datasheet



Version V2.1

Date 2025-01-06

Copyright by Beijing Plink-AI Technology Co., LTD.2023.All rights reserved.

No part of this document may be reproduced or transmitted in any form or by any means without prior written consent of Plink-AI Technologies Co., Ltd.

Notice

The purchased products, services and features are stipulated by the contract made between Plink-AI and the customer. All or part of the products, services and features described in this document may not be within the purchase scope or the usage scope. Unless otherwise specified in the contract, all statements, information, and recommendations in this document are provided "AS IS" without warranties, guarantees or representations of any kind, either express or implied.

The information in this document is subject to change without notice. Every effort has been made in the preparation of this document to ensure accuracy of the contents, but all statements, information, and recommendations in this document do not constitute a warranty of any kind, express or implied.

Please scan code for more products



Website



WeChat Channel

Beijing Plink-AI Technology Co., LTD

Web: <http://www.plink-ai.com/>

Add: Room 1106/1108, Jinyu Jiahua Building, Shangdi 3rd Street, Haidian District, Beijing

Tel: +86-010-62962285/400-127-3302

Document History

Version	Date	Description of Change	Hardware Version
V 1.0	2021-04-25	Preliminary Release	V 1.0
V 1.1	2022-09-08	The pin signal definition of Gigabit wired network connector is modified as follows : Change the 8pin definition: MX2+ to MX1+	V 1.0
V 1.2	2022-09-18	Add product feature description, add content : On-board 64GB industrial-grade EMMC storage granules	V 1.0
V 1.3	2023-05-22	Added the GPIO mapping number and serial port device name of Jetpack5.*	V 1.0
V 2.0	2023-12-28	Modify the product manual template , Added interface test description , Added the function description of ORIN NX series modules.	V 1.0
V 2.1	2025-01-06	Modify font	V 1.0

Hardware Update History

Version	Date	Description of Change
V 1.0	2021-4-25	Initial version



Electronic components and circuits are very sensitive to electrostatic discharge, although the company will design the main interface on the board card to do anti-static protection design, but it is difficult to do anti-static safety protection for all components and circuits. Therefore, it is recommended that you take ESD safety measures when handling any circuit board component.

ESD safety measures include but are not limited to the following:

1. Put the card in an ESD bag during transportation or storage. Do not take out the card until installation and deployment.
2. Before touching the board, release the static electricity stored in the body: Wear a grounding wrist strap.
3. Operate circuit boards only in electrostatic discharge safe areas.
4. Avoid moving circuit boards in carpeted areas.
5. Avoid direct contact with electronic components on the board through edge contact.

Table of Contents

1 Introduction	6
2 Specifications	7
3 External I/O Ports	11
4 All-Round Display	13
5 Connector Description	14
6 Ordering Information	26
7 Recovery Mode	26
8 Method of Application	27
9 GPIO Test	28
10 CAN Test	29
11 Serial Port Test	30
12 Special Instructions	31

1 Introduction

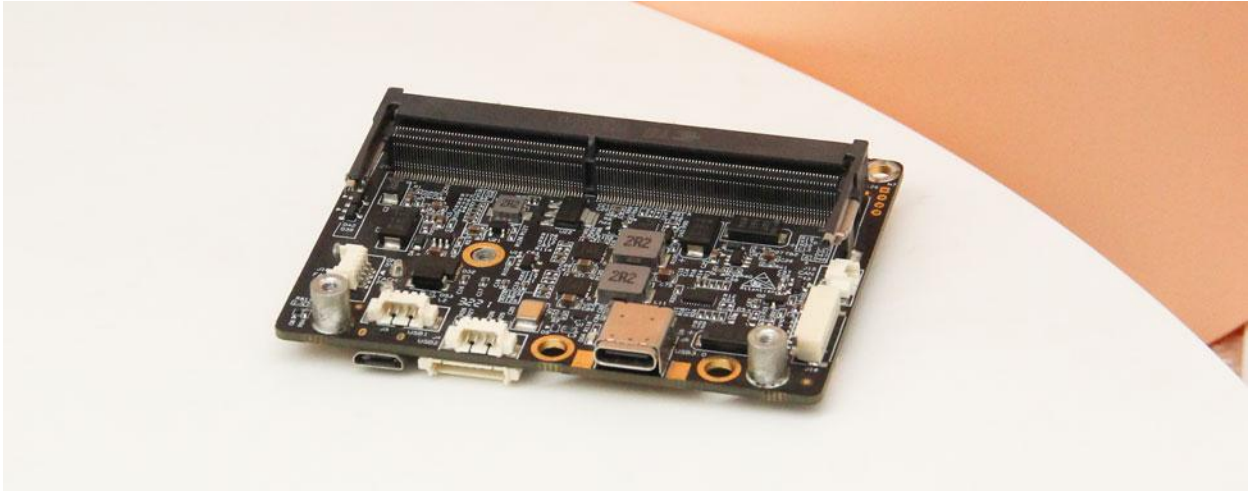

Y-C7 is a low-cost, compact, industrial-grade carrier that can be paired with NVIDIA® Jetson™ Xavier NX, TX2 NX, Nano, ORIN NX, ORIN NANO series core modules. For the intelligent computing application of the UAV industry, the main interface is designed for electrostatic safety protection, and the application scheme of the power supply with high reliability and load capacity of 70W is adopted. The input power supply has overvoltage and reverse polarity protection functions, and has a rich external interface. The whole board device adopts a wide temperature model. In order to meet the requirements of shock resistance of UAV, all interfaces are designed with flexible wires, so as to improve the shock resistance of the connection with peripherals through the unloading of flexible wires. For high-speed USB3.1 signals, a Type-C design with a fixed structure is used to lock Type-C peripherals or conversion cables by screws.

2 Specifications

	Specific
Carrier Board	Y-C7
Module	NVIDIA Jetson Xavier NX / TX2 NX / Jetson NANO / ORIN NX / ORIN NANO Series Modules
Temperature	-40 ~ +85°C
Dimensions (L×W×H)	80mm * 60mm * 16.8mm (Including I/O ports and mounting holes)
Weight	40g

Power Supply	Spec
Input Type	DC
Input Voltage	+9V ~ +24V

I/O Ports

Interface	Quantity	Interface	Quantity
USB3.0 Type-C	1	Micro USB	1
miniPCIe Slot	1	HDMI 2.0	1
MIPI CSI	1	DC power Jack	1
RTC Battery Connector	1	USB 2.0 Connector	1
RS232 serial port	1	TTL serial port	1
M.2 Key E Slot	1	Recovery Connector	1
10/100/1000 BASE-T Ethernet Connector		1	

Note:

When used with the Jetson NANO module, the CAN bus interface function is unavailable, and the M.2 interface is unavailable.

Onboard 64G industrial-grade eMMC storage pellets are not available when used with Jetson ORIN NX or ORIN NANO modules.

NVIDIA Jetson Series Modules Technical Specifications

Module	TX2 NX	Jetson Nano	Xavier NX 16/8GB
AI Performance	1.33 TFLOPS	0.5 TFLOPS	21TOPS
GPU	256-core NVIDIA Pascal™ architecture GPU	NVIDIA Maxwell™ architecture with 128 NVIDIA Cuda® cores	384-core NVIDIA Volta™ architecture GPU with 48 Tensor Cores
CPU	Dual-core NVIDIA Denver™ 2 64-bit CPU and quad-core Arm® Cortex® -A57 MPCore processor	Quad-core ARM® Coretx® -A57 MPCore processor	6-core NVIDIA Carmel Arm®v8.2 64-bit CPU 6MB L2 + 4MB L3
Memory	4GB 128-bit LPDDR4 51.2GB/s	4GB 64-bit LPDDR4 1600MHz-25.6GB/s	16 / 8GB 128-bit LPDDR4x 59.7GB/s
Storage	16GB eMMC 5.1	16GB eMMC 5.1 Flash	16GB eMMC 5.1
Video Encode	1x 4K60 (H.265) 3x 4K30 (H.265) 4x 1080p60 (H.265)	250 MP/sec 1x 4K@30(HEVC) 2x 1080p@60(HEVC) 4x 1080p@30(HEVC)	2x 4K60 (H.265) 4x 4K30 (H.265) 10x 1080p60 (H.265) 22x 1080p30 (H.265)
Video Decode	2x 4K60 (H.265) 7x 1080p60 (H.265) 14x 1080p30 (H.265)	500 MP/sec 1x 4K @ 60 (HEVC) 2x 4K @ 30 (HEVC) 4x 1080p @ 60 (HEVC) 8x 1080p @ 30 (HEVC)	2x 8K30 (H.265) 6x 4K60 (H.265) 12x 4K30 (H.265) 22x 1080p60 (H.265) 44x 1080p30 (H.265)
Power	7.5W - 15W	5W - 10W	10W - 20W
Mechanical	69.6mm x 45mm 260-pin SO-DIMM connector		

Module	Jetson ORIN NX 16GB	Jetson ORIN NX 8GB	Jetson Orin Nano 8GB	Jetson Orin Nano 4GB
AI Performance	100 TOPS	70 TOPS	40 TOPS	20 TOPS
GPU	1024-core NVIDIA Ampere architecture GPU with 32 Tensor Cores		1024-core NVIDIA Ampere architecture GPU with 32 Tensor Cores	512-core NVIDIA Ampere architecture GPU with 16 Tensor Cores
CPU	8-core Arm® Cortex®-A78AE v8.2 64-bit CPU 2MB L2 + 4MB L3	6-core Arm® Cortex®-A78AE v8.2 64-bit CPU 1.5MB L2 + 4MB L3	6-core Arm® Cortex®-A78AE v8.2 64-bit CPU 1.5MB L2 + 4MB L3	
Memory	16GB 128-bit LPDDR5 102.4GB/s	8GB 128-bit LPDDR5 102.4GB/s	8GB 128-bit LPDDR5 68 GB/s	4GB 64-bit LPDDR5 34 GB/s
Storage	Support external NVME			
Video Encode	1x 4K60 (H.265) 3x 4K30 (H.265) 6x 1080p60 (H.265) 12x 1080p30 (H.265)		1080p30 supported by 1-2 CPU cores	
Video Decode	1x 8K30 (H.265) 2x 4K60 (H.265) 4x 4K30 (H.265) 9x 1080p60 (H.265) 18x 1080p30 (H.265)		1x 4K60 (H.265) 2x 4K30 (H.265) 5x 1080p60 (H.265) 11x 1080p30 (H.265)	
Power	10W - 25W	10W - 20W	7W - 15W	7W - 10W

3 External I/O Ports

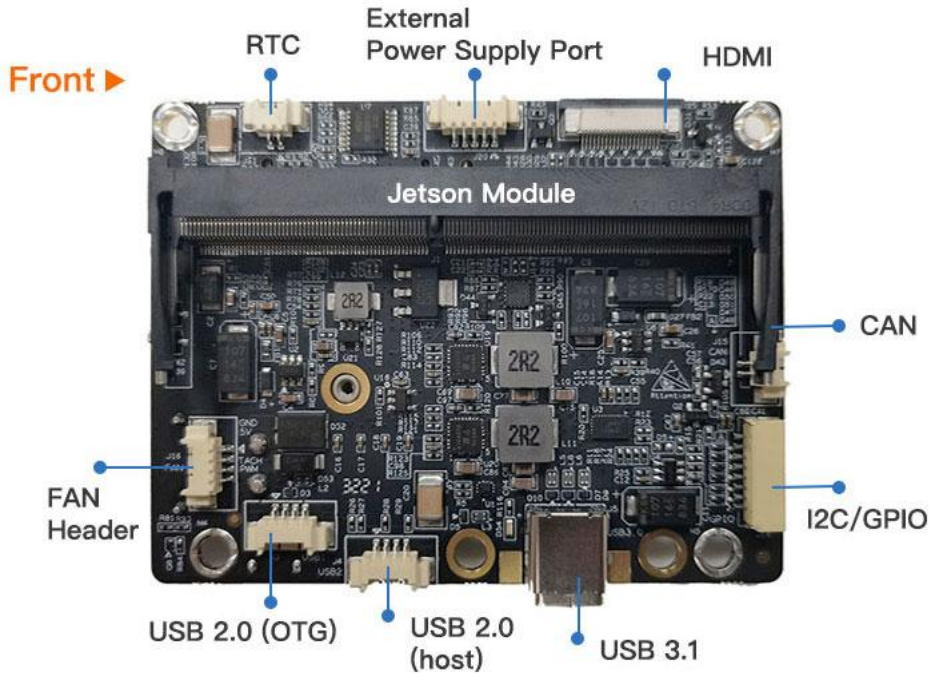

Sign	Function	Sign	Function
J1	Jetson module connector	J4	USB 2.0 connector
J5	USB3.1 Type C Connector	J15	CAN header
J16	Fan Header	J18	I2C & GPIO interface
J21	RTC Battery Socket	J20	External power output
J25	HDMI	J3	USB2.0(OTG, Cannot be used with J2)

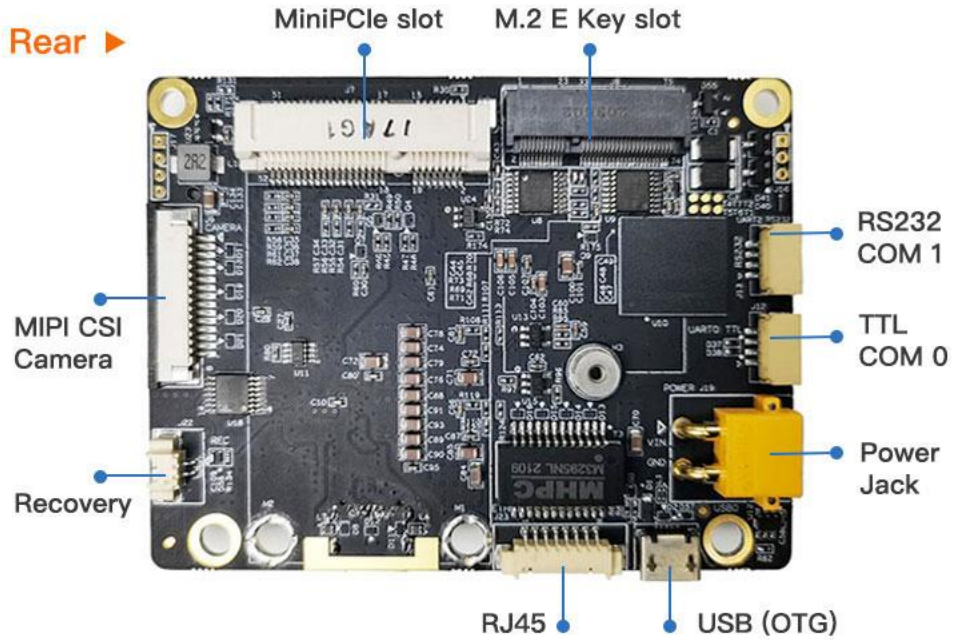

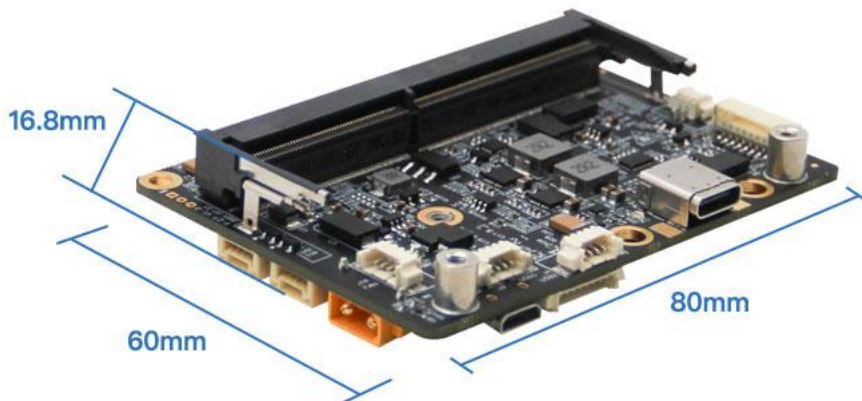
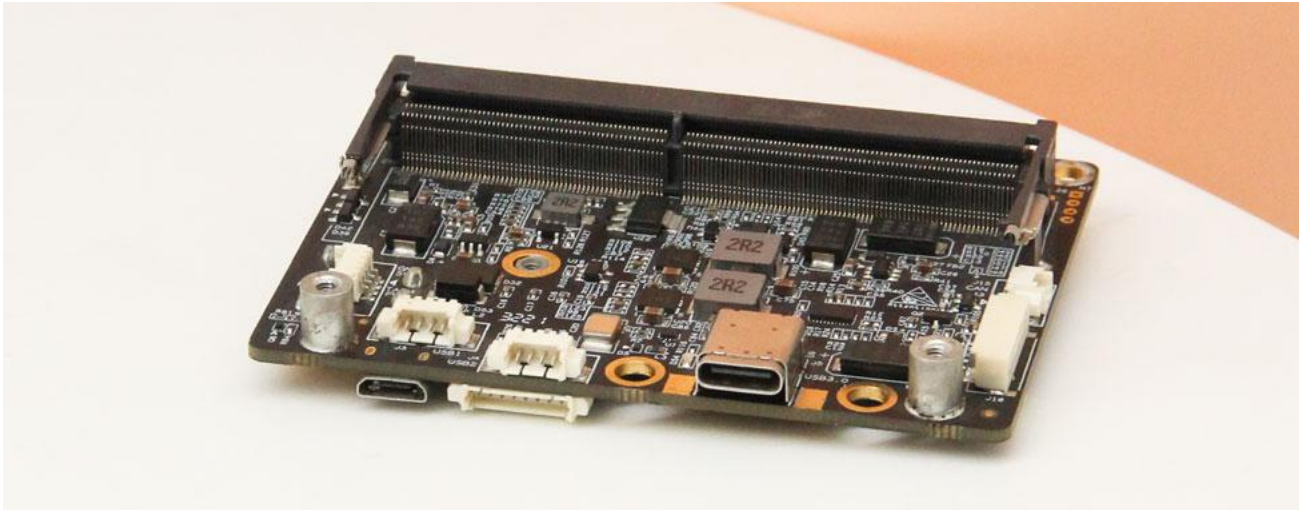

Sign	Function	Sign	Function
J2	Micro USB (OTG)	J8	M.2 Key E Slot
J7	miniPCIe Slot	J19	Power Jack(+9V ~ +24V)
J22	Recovery signal	J12	3.3 V TTL serial port
J13	RS232 serial port	J9	2 Lane MIPI CSI
J23	RJ45 Jack (10/100/1000Mbps Ethernet)		

4 All-Round Display



5 Connector Description

Jetson Module Connector (J1)		
Function	Connect NVIDIA Jetson Xavier NX / TX2 NX / Jetson Nano / Orin NX / Orin Nano Series Modules	
Sign	J1	
Type/Model	SO-DIMM Connector	
Explain	For pin definitions of this connector, refer to the pin definition instructions in the NVIDIA Jetson Xavier NX / TX2 NX / Jetson Nano / Orin NX / Orin Nano series core module datasheet.	

Micro USB 2.0 (J2)																			
Function	USB 2.0 Connector																		
Sign	J2																		
Type/Model	Type-B standard Micro USB 2.0 connector																		
Pin definition	<table border="1"> <thead> <tr> <th>Pin</th> <th>Signal</th> <th>Pin</th> <th>Signal</th> </tr> </thead> <tbody> <tr> <td>1</td> <td>VBUS</td> <td>2</td> <td>USB 2.0 D-</td> </tr> <tr> <td>3</td> <td>USB 2.0 D+</td> <td>4</td> <td>USB ID</td> </tr> <tr> <td>5</td> <td>GND</td> <td></td> <td></td> </tr> </tbody> </table>		Pin	Signal	Pin	Signal	1	VBUS	2	USB 2.0 D-	3	USB 2.0 D+	4	USB ID	5	GND			
Pin	Signal	Pin	Signal																
1	VBUS	2	USB 2.0 D-																
3	USB 2.0 D+	4	USB ID																
5	GND																		
Only support USB OTG mode.																			

USB 2.0 (J4)													
Function	USB 2.0												
Sign	J4												
Type/Model	Molex PicoBlade Header 53261-0471												
Pin definition	<table border="1"> <thead> <tr> <th>Pin</th> <th>Signal</th> <th>Pin</th> <th>Signal</th> </tr> </thead> <tbody> <tr> <td>1</td> <td>VBUS</td> <td>2</td> <td>USB 2.0 D-</td> </tr> <tr> <td>3</td> <td>USB 2.0 D+</td> <td>4</td> <td>GND</td> </tr> </tbody> </table> <p>Pin 1 position: right picture identification.</p>	Pin	Signal	Pin	Signal	1	VBUS	2	USB 2.0 D-	3	USB 2.0 D+	4	GND
Pin	Signal	Pin	Signal										
1	VBUS	2	USB 2.0 D-										
3	USB 2.0 D+	4	GND										



USB3.1 Type C (J5)	
Function	USB3.1
Sign	J5
Type/Model	Standard Type-C Connector
Pin definition	Support positive and negative plug connection, only support DFP mode; Lock thread hole spacing 15mm;



miniPCle Slot (J7)				
Function	miniPCle Slot			
Sign	J7			
Type/Model	5.6mm high, supports full-length and half-length expansion cards			
Pin definition	Pin	Signal	Pin	Signal
	1	PCIE_WAKE	2	3.3V
	3	NC	4	GND
	5	NC	6	1.5V
	7	PCIE_CLKREQ	8	NC
	9	GND	10	NC
	11	PCIE_CLK_N	12	NC
	13	PCLE_CLK_P	14	NC
	15	GND	16	NC
	17	NC	18	GND
	19	NC	20	WI_DISABLE
	21	GND	22	PEIC_RST_N
	23	PCIE_RX_N	24	3.3V
	25	PCIE_RX_P	26	GND
	27	GND	28	1.5V
	29	GND	30	NC
	31	PCIE_TX_N	32	NC
	33	PCIE_TX_P	34	GND
	35	GND	36	NC
	37	GND	38	NC
	39	3.3V	40	GND
	41	3.3V	42	NC
	43	GND	44	NC
	45	NC	46	NC
47	NC	48	1.5V	
49	NC	50	GND	
51	NC	52	3.3V	

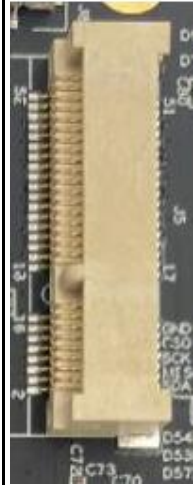

M.2 Key E Slot (J8)

Function	M.2 Key E Slot	
Sign	J8	
Type/Model	E Key ,2242 Size	

Pin definition	Pin	Signal	Pin	Signal	Pin	Signal	Pin	Signal
	1	GND	2	3.3V	3	NC	4	3.3V
	5	NC	6	NC	7	GND	8	NC
	9	NC	10	NC	11	NC	12	NC
	13	NC	14	NC	15	NC	16	NC
	17	NC	18	GND	19	NC	20	NC
	21	NC	22	NC	23	NC	24	NC
	25	NC	26	NC	27	NC	28	NC
	29	NC	30	NC	31	NC	32	NC
	33	GND	34	NC	35	PCIE_TX0_P	36	NC
	37	PCIE_TX0_N	38	NC	39	GND	40	NC
	41	PCIE_RX0_P	42	NC	43	PCIE_RX0_N	44	NC
	45	GND	46	NC	47	PCIE_CLK_P	48	NC
	49	PCIE_CLK_N	50	CLK_32Khz	51	GND	52	PCIE_RST
	53	PCIE_CLKRE Q	54	NC	55	PCIE_WAKE	56	W_DISABL E
	57	GND	58	NC	59	NC	60	NC
	61	NC	62	GPIO10_M2	63	GND	64	NC
	65	NC	66	NC	67	NC	68	NC
	69	NC	70	NC	71	NC	72	3.3V
	73	NC	74	3.3V	75	GND		

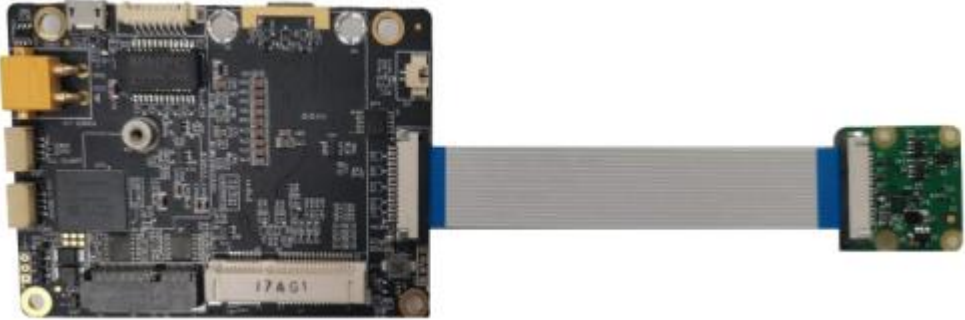
MIPI CSI (J9)				
Function	MIPI CSI Camera Connector			
Sign	J9			
Type/Model	15pin , 1.0mm pitch, Top cover, bottom contact FPC connector			
Pin definition	Pin	Signal	Pin	Signal
	1	VCC_3V3	2	I2C_SDA
	3	I2C_SCL	4	MCLK_1V8
	5	PWDN_1V8	6	GND
	7	CSI_CLK_P	8	CSI_CLK_N
	9	GND	10	CSI_D1_P
	11	CSI_D1_N	12	GND
	13	CSI_D0_P	14	CSI_D0_N
	15	GND		
	Pin 1 position : right picture identification.			
<p>Connection diagram with Raspberry PI 2 generation MIPI camera. Use the same row of cables for connection.</p> 				

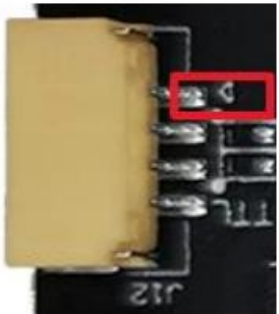

TTL Serial Port UART0 (J12)																							
Function	3.3V TTL Serial Port																						
Sign	J12																						
Type/Model	4Pin, 1.25mm pitch, GH-4PWT																						
Pin definition	<table border="1"> <thead> <tr> <th>Pin</th> <th>Signal</th> <th>Pin</th> <th>Signal</th> </tr> </thead> <tbody> <tr> <td>1</td> <td>3.3V</td> <td>2</td> <td>TX</td> </tr> <tr> <td>3</td> <td>RX</td> <td>4</td> <td>GND</td> </tr> </tbody> </table> <p>The device names in the system are as follows:</p> <table border="1"> <tbody> <tr> <td>Xavier NX</td> <td>/dev/ttyTHS1</td> </tr> <tr> <td>TX2 NX</td> <td>/dev/ttyTHS1</td> </tr> <tr> <td>Jetson Nano</td> <td>/dev/ttyTHS2</td> </tr> <tr> <td>Orin NX</td> <td>/dev/ttyTHS1</td> </tr> <tr> <td>Orin Nano</td> <td>/dev/ttyTHS1</td> </tr> </tbody> </table> <p>Pin 1 position: right picture identification.</p>	Pin	Signal	Pin	Signal	1	3.3V	2	TX	3	RX	4	GND	Xavier NX	/dev/ttyTHS1	TX2 NX	/dev/ttyTHS1	Jetson Nano	/dev/ttyTHS2	Orin NX	/dev/ttyTHS1	Orin Nano	/dev/ttyTHS1
	Pin	Signal	Pin	Signal																			
1	3.3V	2	TX																				
3	RX	4	GND																				
Xavier NX	/dev/ttyTHS1																						
TX2 NX	/dev/ttyTHS1																						
Jetson Nano	/dev/ttyTHS2																						
Orin NX	/dev/ttyTHS1																						
Orin Nano	/dev/ttyTHS1																						
																							

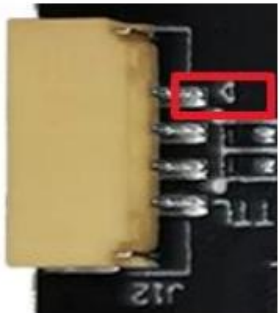
RS232 Serial Port UART1 (J13)																							
Function	RS232 Serial Port																						
Sign	J13																						
Type/Model	4Pin, 1.25mm pitch, GH-4PWT																						
Pin definition	<table border="1"> <thead> <tr> <th>Pin</th> <th>Signal</th> <th>Pin</th> <th>Signal</th> </tr> </thead> <tbody> <tr> <td>1</td> <td>NC</td> <td>2</td> <td>TX</td> </tr> <tr> <td>3</td> <td>RX</td> <td>4</td> <td>GND</td> </tr> </tbody> </table> <p>The device names in the system are as follows:</p> <table border="1"> <tbody> <tr> <td>Xavier NX</td> <td>/dev/ttyTHS0</td> </tr> <tr> <td>TX2 NX</td> <td>/dev/ttyTHS2</td> </tr> <tr> <td>Jetson Nano</td> <td>/dev/ttyTHS1</td> </tr> <tr> <td>Orin NX</td> <td>/dev/ttyTHS0</td> </tr> <tr> <td>Orin Nano</td> <td>/dev/ttyTHS0</td> </tr> </tbody> </table> <p>Pin 1 position: right picture identification.</p>	Pin	Signal	Pin	Signal	1	NC	2	TX	3	RX	4	GND	Xavier NX	/dev/ttyTHS0	TX2 NX	/dev/ttyTHS2	Jetson Nano	/dev/ttyTHS1	Orin NX	/dev/ttyTHS0	Orin Nano	/dev/ttyTHS0
	Pin	Signal	Pin	Signal																			
1	NC	2	TX																				
3	RX	4	GND																				
Xavier NX	/dev/ttyTHS0																						
TX2 NX	/dev/ttyTHS2																						
Jetson Nano	/dev/ttyTHS1																						
Orin NX	/dev/ttyTHS0																						
Orin Nano	/dev/ttyTHS0																						
																							

RS232 Debug Serial Port UART2 (J14)				
Function	RS232 Debug Serial Port UART2			
Sign	J14			
Type/Model	3 holes, 2.0 mm pitch, not welded connectors			
Pin definition	Pin	Signal	Pin	Signal
	1	TX	2	RX
	3	GND		
<p>UART2 is the kernel debugging serial port, used to output c-boot, u-boot, and Linux kernel information. After the Linux kernel is started. UART2 is used as the serial port of the display and control terminal. The default serial port setting : 115200bps, 8N1.</p> <p>Pin 1 position: right picture identification.</p>				



CAN Interface (J15)				
Function	CAN signal interface			
Sign	J15			
Type/Model	Molex PicoBlade Header 53261-0271			
Pin definition	Pin	Signal	Pin	Signal
	1	CAN_H	2	CAN_L
<p>Pin 1 position: right picture identification.</p>				

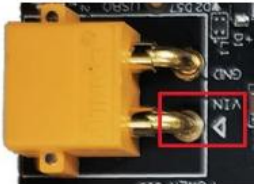

Fan Header (J16)													
Function	4-pin fan header for 5V PWM fan												
Sign	J16												
Type/Model	Molex PicoBlade Header 53261-0471												
Pin definition	<table border="1"> <thead> <tr> <th>Pin</th> <th>Signal</th> <th>Pin</th> <th>Signal</th> </tr> </thead> <tbody> <tr> <td>1</td> <td>GND</td> <td>2</td> <td>+5V</td> </tr> <tr> <td>3</td> <td>TACH</td> <td>4</td> <td>PWM</td> </tr> </tbody> </table>	Pin	Signal	Pin	Signal	1	GND	2	+5V	3	TACH	4	PWM
	Pin	Signal	Pin	Signal									
	1	GND	2	+5V									
3	TACH	4	PWM										
Pin 1 position: right picture identification.													
													

Power Jack (J19)									
Function	Power supply input terminal								
Sign	J19								
Type/Model	XT30PW-M								
Pin definition	<table border="1"> <thead> <tr> <th>Pin</th> <th>Signal</th> <th>Pin</th> <th>Signal</th> </tr> </thead> <tbody> <tr> <td>1</td> <td>VCC(+)</td> <td>2</td> <td>GND(-)</td> </tr> </tbody> </table>	Pin	Signal	Pin	Signal	1	VCC(+)	2	GND(-)
	Pin	Signal	Pin	Signal					
1	VCC(+)	2	GND(-)						
Pin 1 position: right picture identification. Input voltage range: +9V ~+24V									
									

IO Connector (J18)																																																																								
Function	IIC & GPIO signal interface																																																																							
Sign	J18																																																																							
Type/Model	GH-8PWT																																																																							
																																																																								
Pin definition	<table border="1"> <thead> <tr> <th>Pin</th> <th>Signal</th> <th>Pin</th> <th>Signal</th> </tr> </thead> <tbody> <tr> <td>1</td> <td>3.3V</td> <td>2</td> <td>I2C0_SCL</td> </tr> <tr> <td>3</td> <td>I2C0_SDA</td> <td>4</td> <td>GPO1</td> </tr> <tr> <td>5</td> <td>GPIO2</td> <td>6</td> <td>GPIO3</td> </tr> <tr> <td>7</td> <td>GPIO4</td> <td>8</td> <td>GND</td> </tr> </tbody> </table> <p>I2C0 device file names mapped in the system are shown in the following table:</p> <table border="1"> <thead> <tr> <th></th> <th>Xavier NX</th> <th>TX2 NX</th> <th>Nano</th> <th>Orin NX & Orin Nano</th> </tr> </thead> <tbody> <tr> <td>I2C0</td> <td>/dev/i2c-1</td> <td>/dev/i2c-0</td> <td>/dev/i2c-0</td> <td>/dev/i2c-1</td> </tr> </tbody> </table> <p>The resulting GPIO mapping numbers are shown in the following table. GPIO high level voltage is 3.3V. Among then, GPO1 can only be used as an output, providing a current that can directly light the LED lamp bead.</p> <table border="1"> <thead> <tr> <th></th> <th>L4T version</th> <th>GPO1</th> <th>GPIO2</th> <th>GPIO3</th> <th>GPIO4</th> </tr> </thead> <tbody> <tr> <td rowspan="2">Xavier NX</td> <td><= L4T 32.*</td> <td>436</td> <td>422</td> <td>268</td> <td>393</td> </tr> <tr> <td>>L4T 32.*</td> <td>453 (PS.04)</td> <td>441 (PQ.06)</td> <td>321 (PCC.04)</td> <td>419 (PN.01)</td> </tr> <tr> <td>TX2 NX</td> <td></td> <td>396</td> <td>306</td> <td>338</td> <td>269</td> </tr> <tr> <td>Jetson Nano</td> <td></td> <td>216</td> <td>200</td> <td>194</td> <td>38</td> </tr> <tr> <td>Orin NX</td> <td></td> <td>492 (PAC.06)</td> <td>454 (PQ.06)</td> <td>433 (PN.01)</td> <td>391 (PH.00)</td> </tr> <tr> <td>Orin Nano</td> <td></td> <td>492 (PAC.06)</td> <td>454 (PQ.06)</td> <td>433 (PN.01)</td> <td>391 (PH.00)</td> </tr> </tbody> </table> <p>Description: Take the Xavier NX module, GPO1, as an example, if the system version is L4T 32.* , run this command: <code>\$ echo 436 > /sys/class/gpio/export</code> After GPIO is enabled, the corresponding file name is generated: <code>gpio436</code>;</p> <p>Then system version is later then L4T 32.* , run this command: <code>\$ echo 453 > /sys/class/gpio/export</code> After GPIO is enabled the corresponding file name is generated: <code>PS.04</code>.</p>	Pin	Signal	Pin	Signal	1	3.3V	2	I2C0_SCL	3	I2C0_SDA	4	GPO1	5	GPIO2	6	GPIO3	7	GPIO4	8	GND		Xavier NX	TX2 NX	Nano	Orin NX & Orin Nano	I2C0	/dev/i2c-1	/dev/i2c-0	/dev/i2c-0	/dev/i2c-1		L4T version	GPO1	GPIO2	GPIO3	GPIO4	Xavier NX	<= L4T 32.*	436	422	268	393	>L4T 32.*	453 (PS.04)	441 (PQ.06)	321 (PCC.04)	419 (PN.01)	TX2 NX		396	306	338	269	Jetson Nano		216	200	194	38	Orin NX		492 (PAC.06)	454 (PQ.06)	433 (PN.01)	391 (PH.00)	Orin Nano		492 (PAC.06)	454 (PQ.06)	433 (PN.01)	391 (PH.00)
	Pin	Signal	Pin	Signal																																																																				
	1	3.3V	2	I2C0_SCL																																																																				
	3	I2C0_SDA	4	GPO1																																																																				
	5	GPIO2	6	GPIO3																																																																				
	7	GPIO4	8	GND																																																																				
		Xavier NX	TX2 NX	Nano	Orin NX & Orin Nano																																																																			
	I2C0	/dev/i2c-1	/dev/i2c-0	/dev/i2c-0	/dev/i2c-1																																																																			
		L4T version	GPO1	GPIO2	GPIO3	GPIO4																																																																		
	Xavier NX	<= L4T 32.*	436	422	268	393																																																																		
>L4T 32.*		453 (PS.04)	441 (PQ.06)	321 (PCC.04)	419 (PN.01)																																																																			
TX2 NX		396	306	338	269																																																																			
Jetson Nano		216	200	194	38																																																																			
Orin NX		492 (PAC.06)	454 (PQ.06)	433 (PN.01)	391 (PH.00)																																																																			
Orin Nano		492 (PAC.06)	454 (PQ.06)	433 (PN.01)	391 (PH.00)																																																																			

Power Supply Output (J20)				
Function	3.3V & 5V output, peripheral power connector			
Sign	J20			
Type/Model	Molex PicoBlade Header 53261-0571			
Pin definition	Pin	Signal	Pin	Signal
	1	5V	2	GND
	3	GND	4	GND
	5	3.3V		
	Pin 1 position: right picture identification. This port provides a maximum 5V@2A and 3.3V@2A power supply for peripherals.			



RTC Battery Socket (J21)				
Function	Provides power support for the core board clock circuit			
Sign	J21			
Type/Model	Molex PicoBlade Header 53261-0271			
Pin definition	Pin	Signal	Pin	Signal
	1	VCC (3.3V)	2	GND
	Pin 1 position: right picture identification.			



Recovery Signal Interface (J22)				
Function	Recovery Signal input interface			
Sign	J22			
Type/Model	Molex PicoBlade Header 53261-0271			
Pin definition	Pin	Signal	Pin	Signal
	1	Recovery	2	GND
Pin 1 position: right picture identification. When the system is powered on and started, if the Recovery is short connected to GND, the core module enters the Recovery mode and can perform operations such as system burning.				



Ethernet Jack (J23)				
Function	10/100/1000Mbps Ethernet			
Sign	J23			
Type/Model	Molex PicoBlade Header 53261-0871			
Pin definition	Pin	Signal	Pin	Signal
	1	MX4-	2	MX4+
	3	MX3-	4	MX3+
	5	MX2-	6	MX2+
	7	MX1-	8	MX1+



HDMI Connector (J25)				
Function	HDMI Connector			
Sign	J25			
Type/Model	20pin 0.5mm pitch, Bottom contact FPC connector.			
Pin definition	Pin	Signal	Pin	Signal
	1	GND	2	HDMI_TX2_P
	3	HDMI_TX2_N	4	GND
	5	HDMI_TX1_P	6	HDMI_TX1_N
	7	GND	8	HDMI_TX0_P
	9	HDMI_TX0_N	10	GND
	11	HDMI_TXC_P	12	HDMI_TXC_N
	13	GND	14	GND
	15	HDMI_CEC_3V3	16	HDMI_DDC_SCL
	17	HDMI_DDC_SDA	18	HDMI_HPD_1V8
	19	NC	20	VCC_HDMI



6 Ordering Information

Order Type	Function
Y-C7	NVIDIA® Jetson™ Xavier NX / TX2 NX / Jetson Nano / Orin NX / Orin Nano core module is equipped with miniaturized carrier board.

E-commerce Platform

Taobao Store Address: <https://shop333807435.taobao.com/>

Jingdong Store Address: <https://mall.jd.com/index-11467104.html?from=pc>

Ali international Station Address: <https://plink-ai.en.alibaba.com/>

7 Recovery Mode

Jetson core module can work in normal mode and Recovery mode. In Recovery mode, it can perform file system update, kernel update, Bootloader/UEFI update, BCT update and other operations.

To enter the Recovery mode, perform the following steps:

- Power off the system.
- Use a Micro-USB cable to connect the Micro-USB port (J2) of the Y-C7 to the Jetson development host USB port.
- Short-circuit the Recovery signal connector to supply power to the system. Short-circuit the Recovery signal for 3 to 4 seconds.
- When the system enters Recovery mode, you can perform subsequent operations.

8 Method of Application

- Make sure all external system voltages are off.
- Install the Jetson core module onto the J1 high-speed connector. Ensure that the connectors are aligned with even force. After the module is installed in place, install the core module fixing screws.
- Install necessary external cables. (such as: the display line connected to the HDMI display, the power input line for the system power supply, the USB cable connecting the keyboard and mouse...)
- Follow the power input interface (J19) instructions, Connect the power cable to the power supply.(Make sure that the heat dissipation device on the core module is installed before power-on)
- For a system without a protective cover, do not move the hardware system after the system is powered on. Do not touch the circuit board or any electronic components on the circuit board with your body.

9 GPIO Test

Y-C7 leads to the 4-way GPIO of the Jetson core modules. Programmable output voltage 3.3V, please note that the input voltage does not exceed 3.3V.

Take the Xavier NX 8GB module, L4T35.3.1, GPIO1 as an example:

The content after the '#' in the following command is a comment and does not need to be added when executing the command.

- `sudo su`
- `echo 388 > /sys/class/gpio/export # Enable GPIO (Or initialize GPIO)`
- `echo out > /sys/class/gpio/gpio388/direction`
#Set the GPIO input and output directions to out or in.
- `echo 1 > /sys/class/gpio/gpio388/value`
Set the GPIO output high/low level to 1 for high and 0 for low.

#The preceding absolute path name is based on the actual path name generated after GPIO is enabled.

When set to the input state, you can only read values. When set to the output state, you can read and write values.

- `cat /sys/class/gpio/gpio388/value #Get GPIO value.`

The output state can be measured using a multimeter to measure the voltage between the specific lead heel GND.

10 CAN Test

Y-C7 with Jetson module comes standard with one CAN. If you need to connect an external CAN device to test, connect the **CAN_H** of the device to the **CAN_H** of the device under test and the **CAN_L** to the **CAN_L** of the device under test. The test command is as follows:

- `sudo apt-get install busybox can-utils`

#Writes the specified value to a register

- `sudo busybox devmem 0x0c303020 w 0x458`
- `sudo busybox devmem 0x0c303018 w 0x400`
- `sudo busybox devmem 0x0c303010 w 0x458`
- `sudo busybox devmem 0x0c303008 w 0x400`
- `sudo modprobe can` # Load the CAN bus subsystem support module
- `sudo modprobe can_raw` #Load the original CAN protocol module.
- `sudo modprobe mttcan`# Load CAN interface support
- `sudo ip link set can0 type can bitrate 500000`
Set CAN0 bit rate to 500k bps
- `sudo ip link set can1 type can bitrate 500000`
Set CAN1 bit rate to 500k bps
- `sudo ip link set up can0` #Open CAN0
- `sudo ip link set up can1` #Open CAN1
- `candump can0` #Set CAN0 to receive
- `cansend can1 1F223344#1122334455667788`

Open another terminal to send data through CAN1. After sending, there will be data echo at the receiving end of CAN0.

See links for different module register values :

Controller Area Network (CAN) — Jetson Linux Developer Guide
documentation (nvidia.com)

11 Serial Port Test

Y-C7 is equipped with one RS232 serial port and one 3.3V TTL serial port when it is equipped with Jetson module, which can be self-collecting and self-testing of a single serial port. The command is as follows:

- `sudo apt-get install cutecom` #Install the serial port test tool
- `sudo cutecom` # For a single-serial port test, you only need to open one cutecom interface on each terminal. For a two-serial port connection test, use two terminals and open two cutecom interfaces.
- When testing a single serial port, connect the RX of a single serial port to the TX.
- During the test, set the serial port parameters on the cutecom screen and enable the serial port. After the data is output in the input box and sent, the data is displayed in the lower part of the cutecom screen.

The interface of the serial port test tool cutecom is as follows:

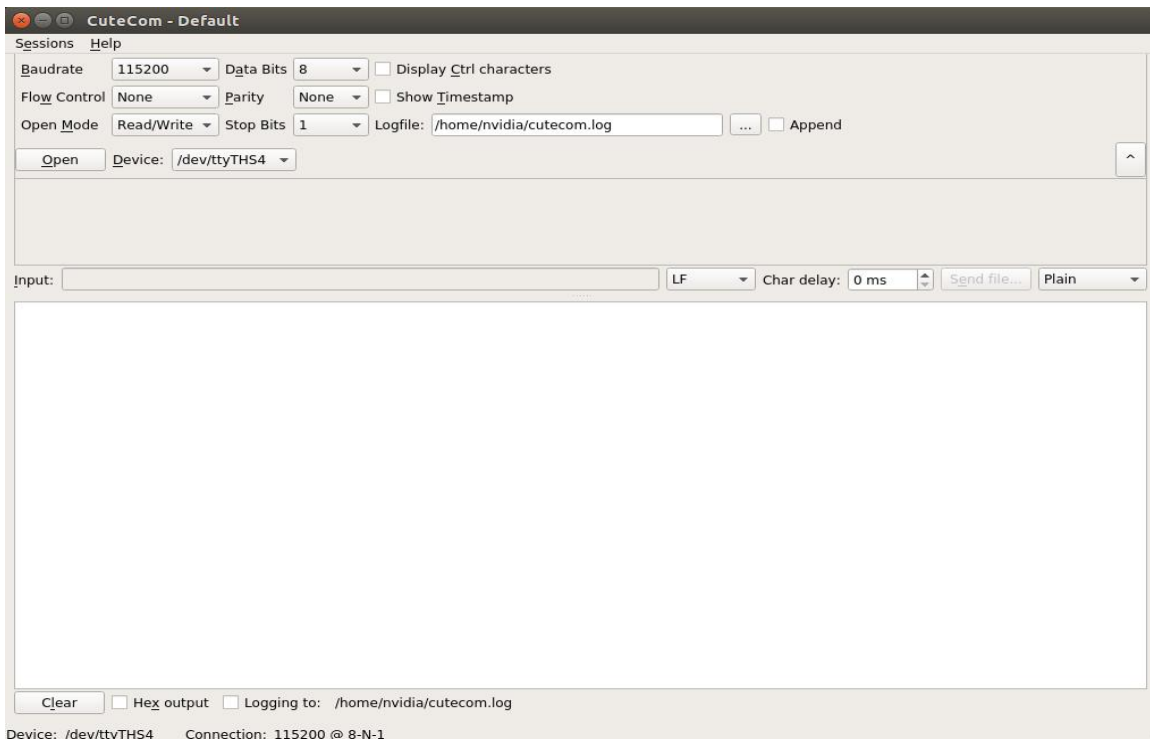

12 Special Instructions

- Initial system username: **nvidia** , password: **nvidia** , no password su. If root permissions are required, use sudo to grant permissions, or use sudo su to access the root user.
- The pre-installed system is pure by default and does not contain Jetpack software. You can use the following command to install the software. Do not replace or modify the default software source before installation:
 - `sudo apt-get update`
 - `sudo apt-get install nvidia-jetpack`
- It can also be installed over the network using SDKmanager software.
- For more information please refer to :Jetson wiki (plink-ai.com)